

DATI TECNICI  
 TECHNICAL SPECIFICATIONS  
 CARACTERISTIQUES TECHNIQUES  
 DATOS TÉCNICOS

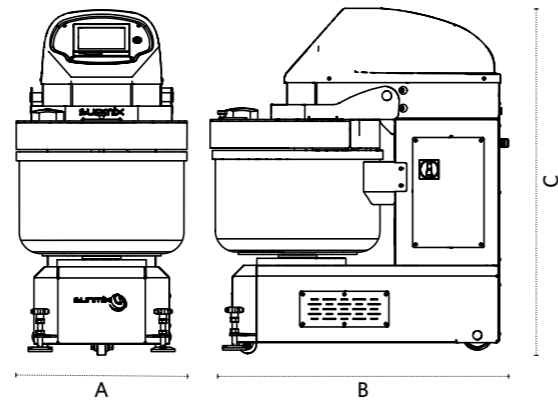

centrostampaschio.com

2 motori/2 motors 400V | 50Hz | 3Ph

Modello Model Modèle Modelo	Capacità impasto Dough capacity Capacité de pâte Capacidad de masa kg	Capacità farina Flour capacity Capacité de farine Capacidad de harina kg	Volume vasca Bowl volume Volume de la cuve Volumen cuva lit	Motore spirale Spiral arm motor Moteur spirale Motor espiral kw	Motore vasca Bowl motor Moteur cuve Motor cuva kw	Peso Weight Poids Peso kg	Dimensioni / Dimensions Dimensions / Dimensiones		
							A cm	B cm	C cm
QUEEN 30-2	30	18	45	2.2	0.37	171	48	80	102
QUEEN 40-2	40	25	55	2.2	0.37	171	54	85	102
QUEEN 50-2	50	32	67	3	0.37	230	54	95	110
QUEEN 60-2	60	36	81	3	0.37	230	59	100	110
QUEEN 80-2	80	50	131	5.5	0.55	330	73	120	140
QUEEN 120-2	120	80	190	5.5	0.55	330	78	125	140
QUEEN 160-2	160	100	266	11	0.75	660	87	143	157
QUEEN 200-2	200	125	306	11	0.75	680	93	146	157
QUEEN 250-2	250	150	370	15	1.1	800	103	155	165
QUEEN 300-2	300	185	450	15	1.1	850	108	163	165



**sunmix**  
 NEW GENERATION MACHINES



ROSSO RUBINO



NERO PROFONDO



BIANCO PURO



Sunmix Srl  
 Via Lago di Vico, 4 - 36015 Schio (VI) Italy  
 Tel. +39 0445 640559 - info@sunmix.it  
 P. IVA / C.F. 04250510247 - www.sunmix.it



SPIRAL MIXER  
**QUEEN**



DOSATORE D'ACQUA SUNMIX  
SUNMIX WATER DOSER  
DOSEUR D'EAU SUNMIX  
DOSIFICADOR DE AGUA SUNMIX



## I

### IMPASTATRICI A SPIRALE QUEEN LINE

Impastatrici con 2 motori, voltaggio 400V/50Hz/3ph, dotata di inversione di marcia. Ideali per impasti a partire dal 50% di idratazione e per un utilizzo intenso.

### PANNELLO COMANDI TOUCH SCREEN

Permette di memorizzare fino a 12 diverse ricette in 12 step ognuna, garantendo impasti sempre costanti e di elevata qualità.

### SENSORE DI TEMPERATURA A RAGGI INFRAROSSI

Misura la temperatura istantanea dell'impasto, mantenendolo sempre sotto controllo. È possibile impostare una temperatura massima che permette di fermare l'impastatrice al raggiungimento di tale temperatura.

### LUCI LED PER ILLUMINARE L'IMPASTO

Illuminano l'interno vasca permettendo di tenere sotto controllo l'impasto in tutte le fasi di lavorazione.

### INVERTER

Grazie al doppio inverter la velocità di spirale e vasca possono essere regolate separatamente e adattate a diversi tipi di impasto, variando da 70 a 300 rpm per la spirale e da 8 a 30 rpm per la vasca.

### RIPARO CHIUSO

Garantisce una maggiore igiene ed evita la fuoriuscita delle polveri durante tutte le fasi di lavorazione.

### COLORI STANDARD

Rosso rubino, Nero profondo, Bianco puro. Altri colori su richiesta.

### OPTIONAL:

- DOSATORE D'ACQUA SUNMIX invia automaticamente all'interno della vasca la quantità d'acqua impostata nella ricetta, riducendo così i tempi di produzione e garantendo quantità sempre costanti.
- WI-FI per industria 4.0.

## EN

### QUEEN LINE SPIRAL MIXERS

Mixers with 2 motors, voltage 400V/50Hz/3ph, with bowl reverse. Perfect for dough from 50% of hydration and for heavy-duty use.

### TOUCH SCREEN CONTROL PANEL

It allows to memorize up to 12 different recipes in 12 steps each, guaranteeing constant doughs of high quality.

### INFRARED RAYS TEMPERATURE SENSOR

It detects the instant dough temperature, keeping it always under control. It's possible to set a maximum temperature that allows to stop the mixer in case of achievement of this temperature.

### LED LIGHTS TO ILLUMINATE THE DOUGH

They light the inside of the bowl allowing to keep the dough under control in all its working steps.

### INVERTER

Thanks to the double inverter the speed of spiral and bowl can be adjusted separately and adapted to different kind of dough, changing from 70 to 300 rpm for the spiral and from 8 to 30 rpm for the bowl.

### CLOSED PROTECTION

It guarantees a higher hygiene and it avoids the emissions of powders in all the working phases.

### STANDARD COLORS

Rosso rubino, Nero profondo, Bianco puro. Other colors upon request.

### OPTIONALS:

- SUNMIX WATER DOSER, it automatically sends inside the bowl the water quantity set on the recipe, reducing the production time and guaranteeing always constant quantities.

## F

### PÉTRIN À SPIRALE QUEEN LINE

Pétrin avec 2 moteurs, voltage 400V/50Hz / 3ph, avec inversion de la cuve. Idéal à partir de 50% hydratation et utilisation intense.

### PANNEAU DE COMMANDE À ÉCRAN TACTILE

Interface vous permettant de stocker jusqu'à 12 différentes recettes en 12 programmations différentes, garantissant des pâtes toujours constantes et de haute qualité.

### CAPTEUR DE TEMPÉRATURE INFRAROUGE

Mesure et maintient instantanément la température de la pâte sous contrôle. Il vous permet de régler une température maximale à laquelle le pétrin s'arrêtera une fois atteinte.

### ÉCLAIRAGE LED DE LA CUVE

Cela vous garantit une excellente visibilité de vos empâtements durant toutes les phases de traitement.

### VARIATEUR DE VITESSE

Intégrant 2 onduleurs, la vitesse de la spirale et de la cuve peuvent être adaptées aux types de pâtes. Elles peuvent varier indépendamment, de 70 à 300 rpm pour la spirale et de 8 à 30 rpm pour la cuve.

### PROTECTION FERMÉE

Garanti une meilleure hygiène et évite tout passage de poussière durant toutes les étapes.

### COULEURS STANDARDS

Rosso rubino, Nero profondo, Bianco puro. Autres coloris sur demande.

### OPTIONAL:

- DOSEUR D'EAU SUNMIX distribue automatiquement à l'intérieur de la cuve la quantité d'eau programmée dans la recette, réduisant ainsi les temps de production et garantissant des quantités constantes.

## ES

### AMASADORAS DE ESPIRAL QUEEN LINE

Amasadoras con 2 motores, voltaje 400V/50Hz/3ph, con inversión de la cuva. Perfecta para masas desde el 50% de hidratación y para un uso intensivo.

### PANTALLA TÁCTIL DE CONTROL

Permite memorizar hasta 12 diferentes recetas en 12 pasos cadauna, garantizando masas siempre iguales y de elevada calidad.

### SENSOR DE TEMPERATURA CON RAYOS INFRARROJOS

Mide la temperatura instantánea de la masa, manteniendola siempre bajo control. Es posible establecer la temperatura máxima que permite arrestar la amasadora al logro de dicha temperatura.

### LUCES PARA ALUMBRAR LA MASA

Permiten controlar constantemente la masa durante todas las etapas de preparación.

### INVERSOR

Gracias al doble inductor la velocidad de espiral y cuva se pueden arreglar separadamente y adaptadas al tipo de masa, variando desde 70 hasta 300 rpm para la espiral y desde 8 hasta 30 rpm para la cuva.

### PROTECCIÓN CERRADA

Garantiza más higiene y evita el escape de polvos durante todas las fases de trabajo.

### COLORES DE SERIE

Rosso rubino, Nero profondo, Bianco puro. Otros colores a pedido.

### OPTIONAL:

- DOSIFICADOR DE AGUA SUNMIX, invía en automático en la cuva la cantidad de agua programada en la receta, reduciendo así el tiempo de producción y garantizando una calidad siempre constante.

